

**Benchscale Testing of Photocatalytic
Oxidation (PCO) to Destroy Volatile
Organic Compound (VOC) Emissions**

SEMATECH

Technology Transfer 95042791A-ENG

SEMATECH and the **SEMATECH logo** are registered service marks of SEMATECH, Inc.

Benchscale Testing of Photocatalytic Oxidation (PCO) to Destroy Volatile Organic Compound (VOC) Emissions

Technology Transfer # 95042791A-ENG

SEMATECH

April 28, 1995

Abstract: This interim report addresses the results of testing photocatalytic oxidation (PCO) (at the bench) of simulated organic air emissions from a parts cleaning sink conducted as part of SEMATECH's S66 Air Emissions project. The simulated effluent stream contained equal parts isopropanol, acetone, and methanol, at a total concentration of 400 ppmv. Under the conditions examined, >95% of the incoming pollutants were converted to carbon dioxide and water. Although high conversion rates were achieved, initial scale-up calculations indicate that process optimization is needed to achieve faster reaction rates.

Keywords: Cleaning Equipment, Emissions Control, Volatile Organic Compounds

Authors: Craig S. Turchi, Roberto Rabago

Approvals: Avtar S. Jassal, Author, Project Manager
Phyllis Pei, Program Manager
Ray Kerby, Director, Environment, Safety, & Health
Laurie Modrey, Technical Information Transfer Team Leader

Table of Contents

| | | |
|-----|---------------------------------------|----|
| 1 | EXECUTIVE SUMMARY..... | 1 |
| 2 | INTRODUCTION..... | 1 |
| 3 | EXPERIMENTAL DATA..... | 2 |
| 3.1 | Size and Cost Analysis | 8 |
| 4 | CONCLUSIONS AND RECOMMENDATIONS | 11 |
| 5 | FUTURE WORK..... | 12 |
| 6 | REFERENCES | 12 |

List of Figures

| | | |
|----------|---|----|
| Figure 1 | Simplified Schematic of a Laboratory Photocatalytic Oxidation System..... | 3 |
| Figure 2 | Methanol Conversion in a Laboratory PCO Reactor (duplicate runs are shown)..... | 4 |
| Figure 3 | Acetone Conversion in a Laboratory PCO Reactor (duplicate runs are shown)..... | 5 |
| Figure 4 | Isopropanol Conversion in a Laboratory PCO Reactor (duplicate runs are shown)..... | 5 |
| Figure 5 | Three Component Mixture Conversion in a Laboratory PCO Reactor | 7 |
| Figure 6 | Conversion of the Simulated Parts Cleaning Sink Emissions in a Laboratory PCO Reactor | 7 |
| Figure 7 | Conversion of the Simulated Parts Cleaning Sink Emissions at 70°C | 8 |
| Figure 8 | Sequence of PCO Cost Modeling | 10 |
| Figure 9 | Effect of Oxidant Addition on Rate of Ethanol Degradation | 11 |

List of Tables

| | | |
|---------|--|---|
| Table 1 | Parts Cleaning Sink Effluent Air Stream Characteristics | 2 |
| Table 2 | Estimated Costs for PCO Treatment of the Simulated Air Emissions from a Parts Cleaning Sink..... | 9 |

1 EXECUTIVE SUMMARY

This interim report addresses the results of testing the photocatalytic oxidation (at the bench) of simulated organic air emissions from a parts cleaning sink.

The simulated effluent stream contained equal parts isopropanol, acetone, and methanol, at a total concentration of 400 parts per million by volume (ppmv). Under all the conditions examined, >95% of the volatile organic compounds (VOCs) was destroyed. At a slightly elevated temperature (70°C), the reaction rates are three to four times faster than at room temperature; however, at this temperature a small fraction (approximately 6%) of the incoming carbon is converted to carbon monoxide.

The laboratory results have demonstrated high conversion to carbon dioxide and water; however, scale-up calculations suggest that further optimization of the process is needed to lower the cost of ownership.

2 INTRODUCTION

This document is the interim benchscale treatability and cost analysis report under the Cooperative Research and Development Agreement between National Renewable Energy Laboratory (NREL) and SEMATECH. The purpose of the S66 Air Emissions project is to evaluate photocatalytic oxidation (PCO) as an abatement technology for air emissions from semiconductor fabs. NREL, a Department of Energy facility, has been actively involved in PCO research since 1989.

PCO uses a photochemical reaction, rather than a thermal process, to destroy contaminants in air or water. Ultraviolet (UV) light used with a semiconductor photocatalyst—commonly titanium dioxide (TiO₂)—breaks down organic chemicals into carbon dioxide and water. If chlorinated compounds are present, HCl will also be formed. Systems designed to treat chlorinated compounds include an acid gas scrubber. The process can use electric lamps or sunlight. PCO offers many advantages as an option for pollutant destruction:

- Achieves high destruction efficiency
- Operates at ambient or near ambient temperature and pressure
- Uses an inexpensive, safe catalyst
- Creates no oxides of nitrogen (NO_x)
- Requires no auxiliary fuel
- Treats very low concentrations of pollutants effectively
- Employs a modular design

To support technology commercialization, NREL is currently conducting a multi-million dollar research program on various aspects of PCO. The program involves partnerships with Sandia National Laboratories, SEMATECH, International Technology (IT) Corporation, Arizona State University, and several other companies and universities. IT Corporation is a key partner in this development team, with its NEPCCO subsidiary as one of the nation's leading suppliers of air pollution abatement equipment. Arizona State has separate agreements with NREL and the Semiconductor Research Corporation to investigate the fundamental processes involved in PCO. NREL's researchers are directly involved in

- Analyzing chemical processes, products, and intermediates
- Researching the reactivity of catalysts
- Evaluating the treatability of organic and inorganic pollutants
- Developing engineering models to calculate process size and cost

PCO has a wide variety of potential applications. The application closest to commercialization is the destruction of certain VOCs in air. The PCO process can be applied directly to airborne emissions (air pollutants) as well as to gaseous pollutants generated from remediation techniques (e.g., soil vapor extraction and air stripping).

The goal of this project is to determine the feasibility of treating VOC emissions from semiconductor plants. Representative exhaust streams using simulated gas streams are being benchscale-tested at NREL. The results of these tests will be verified using a slip stream from a semiconductor facility. The benchscale tests will be used to collect key design and operating parameters for the PCO technology so that system size and cost can be estimated. This report documents the results of testing on the first simulated air stream—solvent vapor emissions from a parts cleaning sink.

3 EXPERIMENTAL DATA

SEMATECH and NREL jointly selected the first stream to be the emissions from a parts cleaning sink. Characteristics of this stream are shown in Table 1.

Table 1 Parts Cleaning Sink Effluent Air Stream Characteristics

| Characteristic | Value |
|-------------------|--------------------------------|
| VOCs | Acetone, isopropanol, methanol |
| Concentration | 400 ppmv total VOC |
| Temperature | Ambient (25°C) |
| Pressure | Ambient |
| Relative Humidity | 50% |
| Flow Rate | 400 scfm |

The laboratory photoreactor used in these experiments is an annular design in which the inner wall of the annulus is formed by an 8 watt (W), low pressure fluorescent black light. The outer wall is a piece of borosilicate glass process pipe. A known amount of catalyst is coated onto the

inner wall of the glass sleeve. Exact photon output from the lamp is measured periodically with a UV spectroradiometer.

The photoreactor is incorporated into a test system that allows researchers to vary flow rate, waste composition, humidity, and temperature. A simplified schematic is shown in Figure 1. The system is designed to be run in either a single-pass or recirculating mode, depending on the requirements of the experiment. Several experiments to characterize the photocatalytic destruction of the VOCs in the air stream were conducted using this apparatus.

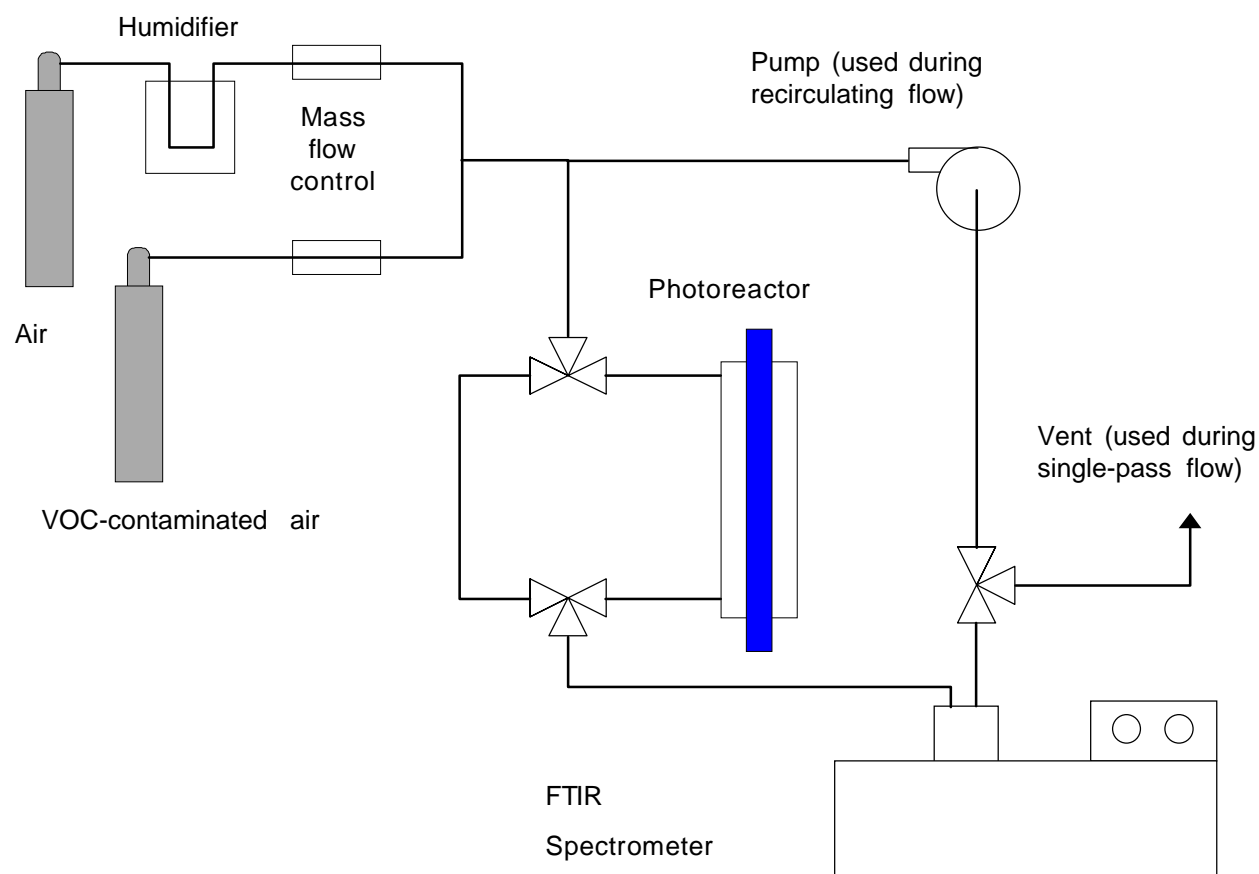

Figure 1 Simplified Schematic of a Laboratory Photocatalytic Oxidation System

Figures 2, 3, and 4 show the results of experiments with the individual reactants. These plots show that the various reactants and products disappear or evolve as a function of residence time within a recirculating system. Duplicate tests are shown on each plot. Each of the three compounds show >95% of VOCs convert to carbon dioxide and water in a residence time of 2 seconds or less. Trace amounts of carbon monoxide were detected. Methanol and acetone were converted to carbon dioxide, with no intermediate species noted. Isopropanol was converted to acetone before being converted to carbon dioxide and water. Although specific tests for other possible intermediates were not conducted, no unknown peaks were seen in the infrared spectra of the samples. The infrared analyzer is able to detect virtually any gas-phase compound (except diatomic molecules such as oxygen) to a level of 5 ppmv or less. Thus, the absence of unidentified peaks, coupled with the good carbon balance closure based on evolved carbon dioxide, is strong evidence that the reaction proceeds to near complete oxidation of the organics.

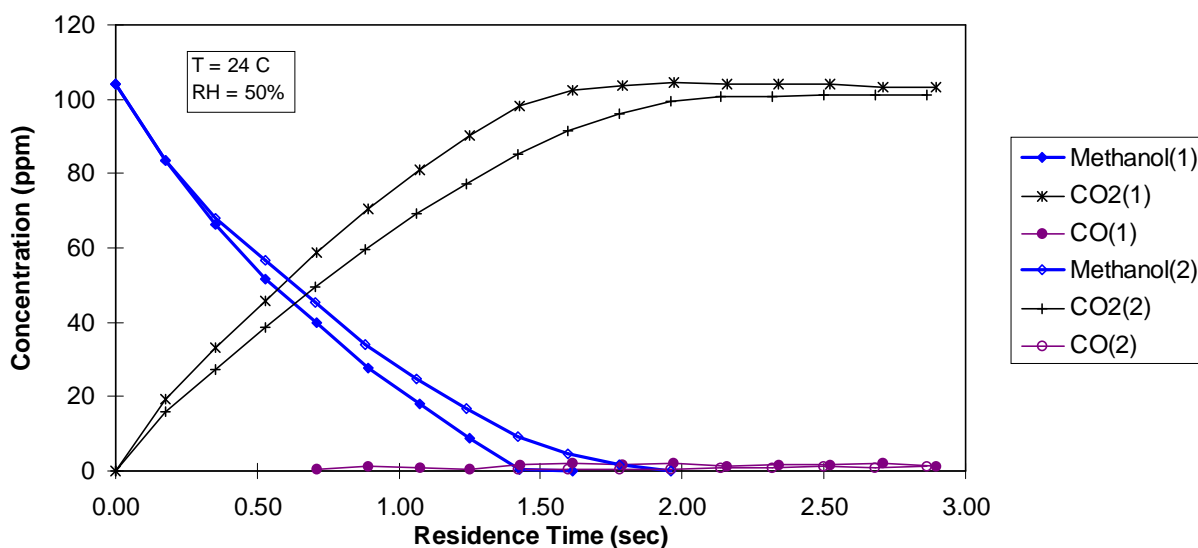

Figure 2 Methanol Conversion in a Laboratory PCO Reactor (duplicate runs are shown)

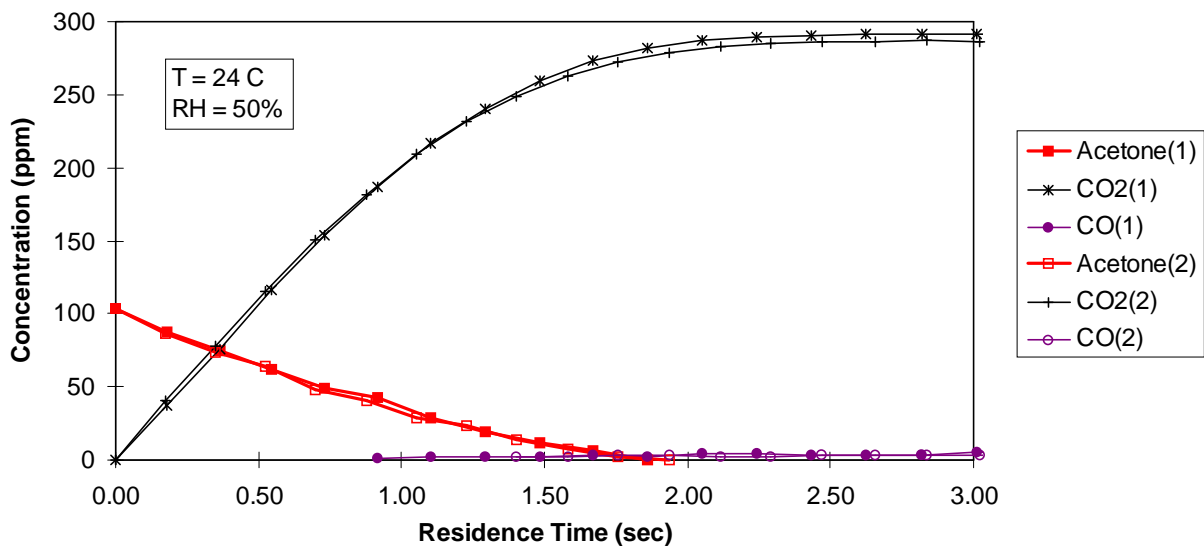

Figure 3 Acetone Conversion in a Laboratory PCO Reactor (duplicate runs are shown)

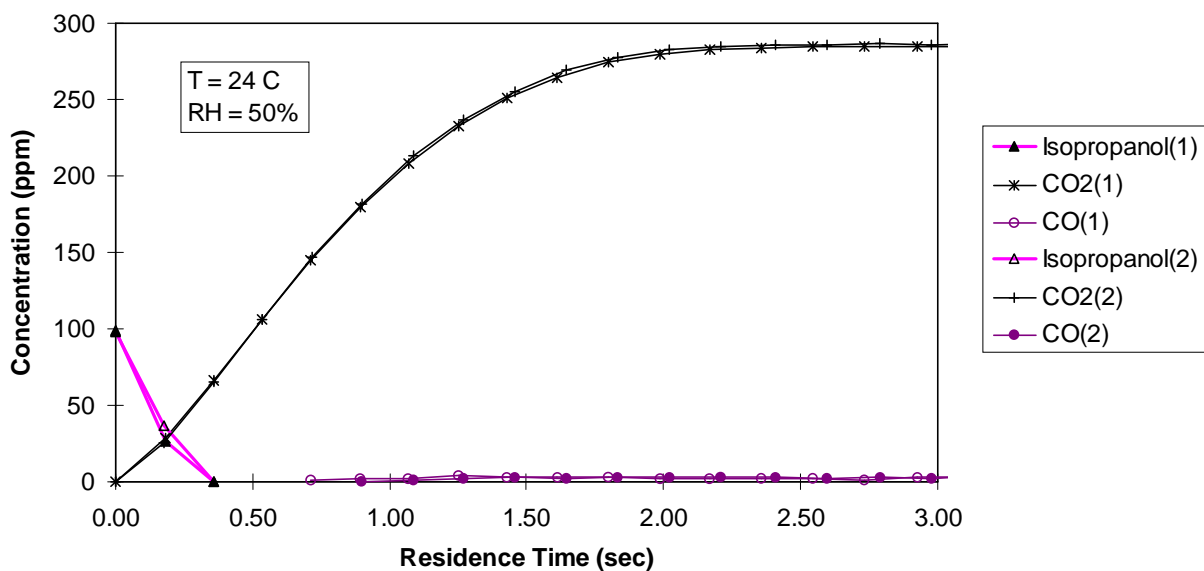
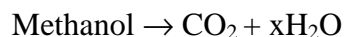
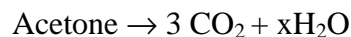

Figure 4 Isopropanol Conversion in a Laboratory PCO Reactor (duplicate runs are shown)

These single component data, coupled with results obtained at different initial concentrations, were used to develop a kinetic model of the photocatalytic reaction. The reaction stoichiometry was depicted as follows:



This simple representation of the destruction process provided a suitable means of modeling the PCO reaction. With this model, the size of a full-scale system can be estimated on the basis of the laboratory data.

Following the single component experiments, the complete mixture was tested. The first runs (e.g., Figure 5) had an initial concentration of about 30 ppmv per compound. The Fourier transform infrared spectroscopy (FTIR) analyzer used for monitoring gas concentrations is calibrated up to only 300 ppmv for carbon dioxide, and lower starting concentrations were necessary to be able to verify conversion to CO_2 . Water evolution is not tracked because the small amount generated is overwhelmed by the 50% relative humidity already in the air stream. For the initial concentrations of VOCs in Figure 5, 100% conversion should yield 191 ppmv CO_2 . As shown in Figure 5, the carbon balances closed to within 2% (the level of experimental error), indicating that few, if any, other organic species were formed. Also the acetone concentration initially increases as it is formed by the destruction of isopropanol. The next runs represent the air stream as characterized in Table 1. As shown in Figure 6, the trends are similar to those seen at the lower concentrations: rapid disappearance of methanol and isopropanol, formation and destruction of acetone, and conversion to CO_2 . Carbon dioxide could be quantified up to only 300 ppmv; however, the CO_2 concentration did level off after approximately 4 seconds. Based on the good carbon balance closure seen in Figures 2 through 5 and the absence of any detectable intermediates, the point where CO_2 concentration levels off represents greater than 95% conversion. A higher concentration calibration gas has been ordered to allow CO_2 to be quantified up to 1000 ppmv.

The lines on Figure 6 are model estimates based on the single component data. These curves demonstrate the important ability of the model to predict the destruction rate of a mixture of VOCs using previously obtained data on the individual components. This accurate modeling is critical to the estimation of full-scale system size.

The next step was to investigate the effect of temperature on the observed destruction rate. Previous data suggested that increasing temperature might aid the reaction. However, in PCO systems there are two competing effects of temperature. PCO reactions occur in two steps: the reactants adsorb on the catalyst surface and subsequently react. Increasing temperature should speed the reaction step but will also slow the adsorption process. The data in Figure 7 show the results of increasing the reaction temperature to 70°C . When compared to the room temperature data (Figure 6) the rate of conversion increases significantly, corresponding to an increase of a factor of three to four in reaction rate. Carbon monoxide (CO) also forms at higher temperatures. Apparently a small percentage (roughly 6%) of the organic carbon is converted into CO during the photoreaction. Carbon monoxide can be further converted to CO_2 by including a co-catalyst in the photoreactor.

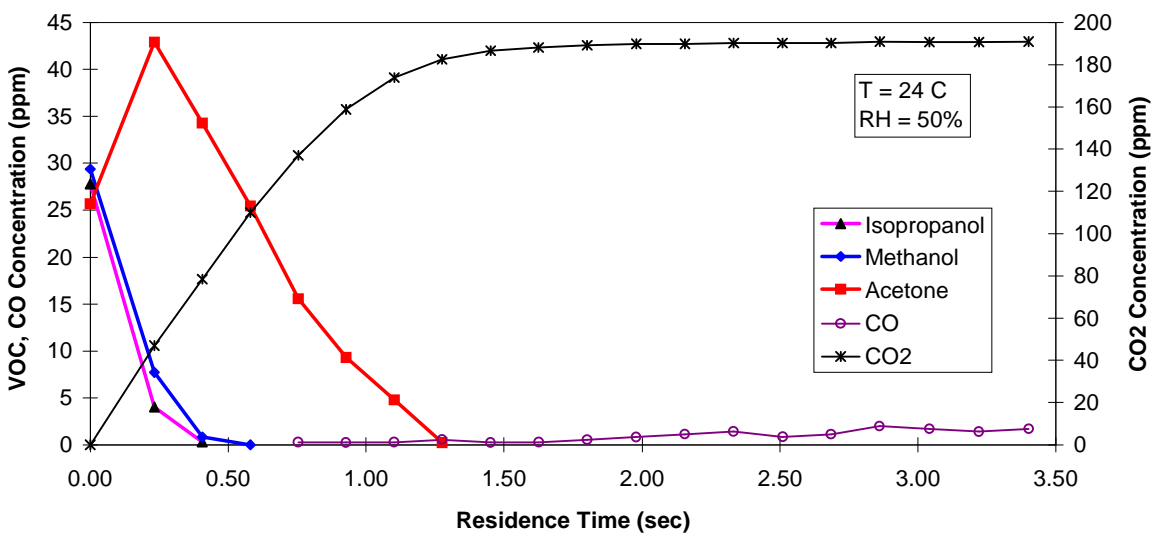

Figure 5 Three Component Mixture Conversion in a Laboratory PCO Reactor

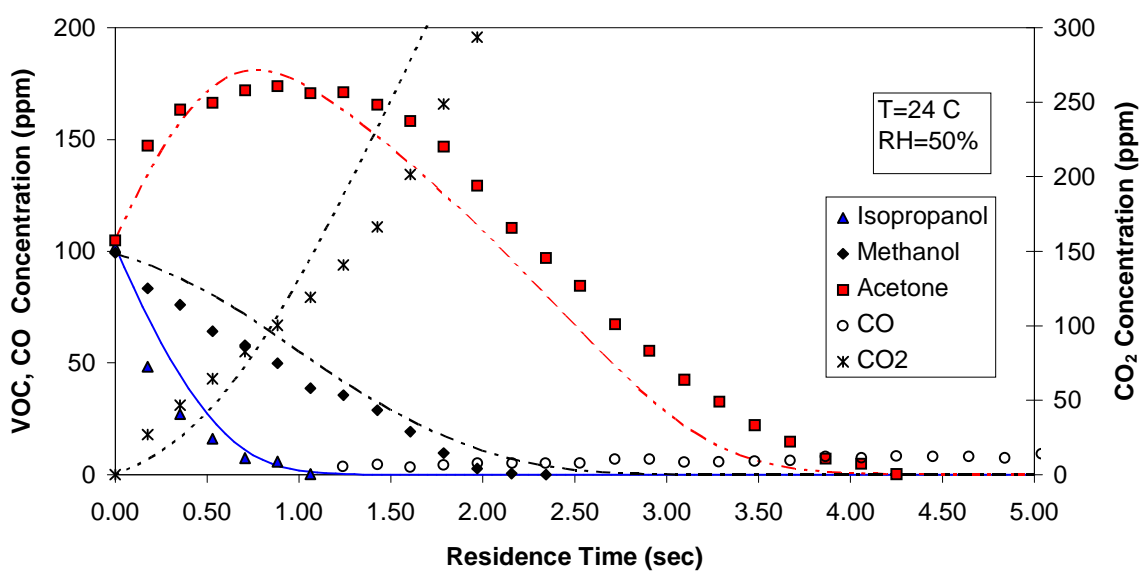

Figure 6 Conversion of the Simulated Parts Cleaning Sink Emissions in a Laboratory PCO Reactor

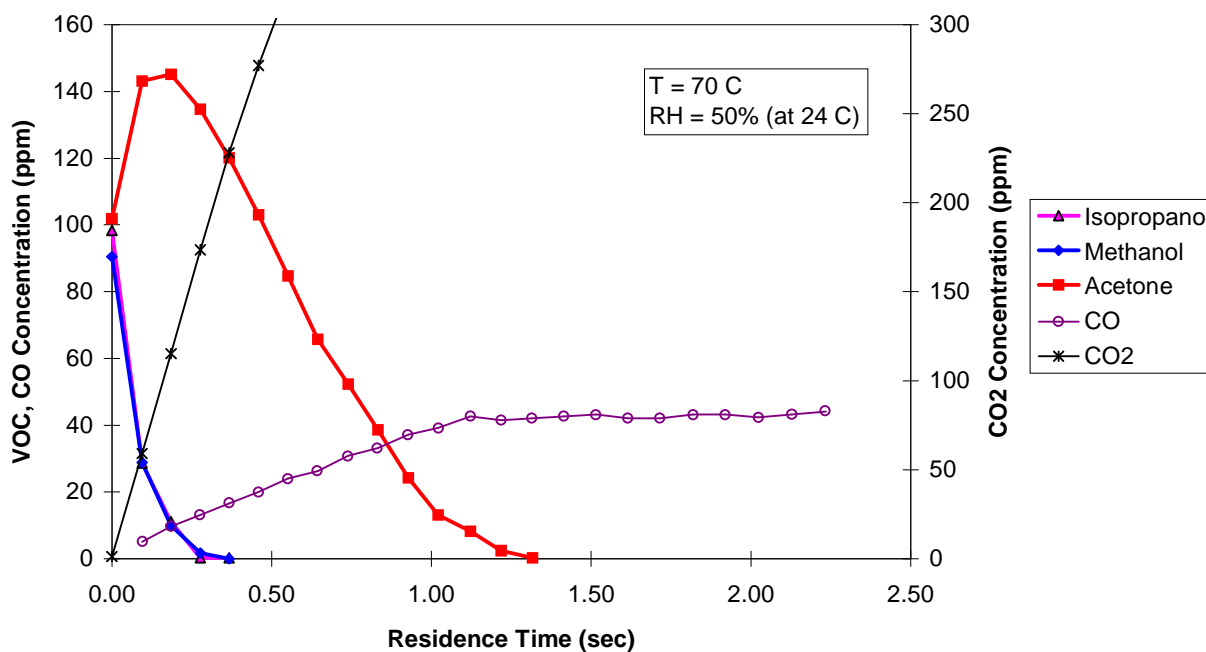

Figure 7 Conversion of the Simulated Parts Cleaning Sink Emissions at 70°C

3.1 Size and Cost Analysis

IT Corporation and NREL developed a computer simulation to predict the performance of the PCO system. The first step uses the laboratory data and the known characteristics of the test system to determine fundamental rate parameters for the pollutants. These rate parameters can be used to estimate the size of a full-scale system. Figure 6 demonstrated how the kinetic model could use individual component data to predict the destruction rate for a mixture of VOCs. The next step in the modeling process is to use data from the laboratory to predict the performance of a full-size unit. Once the full-scale size is determined, a cost routine is used to evaluate the capital and operating costs of the system. NREL has developed its own costing routine [1] based on methods used by the American Institute of Chemical Engineer's Center for Waste Reduction Technologies [2,3]. SEMATECH's Cost of Ownership model is similar, although this routine had to be modified by TRC Environmental to be suitable for costing abatement technologies. Both routines depend on an estimate (the same estimate) of a treatment unit's capital cost and utility requirements. However, the two routines differ somewhat in the various assumed economic factors and costs. For consistency with TRC's other work, cost results are based on their routine. Results for the cost analysis are shown in Table 2. The entire cost estimation procedure is summarized in Figure 8.

The estimates shown in Figure 8 assume the PCO system is operating at 70°C.

Table 2 Preliminary Estimated Costs for PCO Treatment of the Simulated Air Emissions from a Parts Cleaning Sink

| Characteristic | Value |
|---|--|
| Air Stream | 400 scfm, 400 ppmv VOC (see Table 1) |
| Estimated system size | 86 kW |
| Estimated equipment cost | \$141,000 |
| Principle assumptions in the SEMATECH cost of ownership model as modified by TRC: | |
| Installation and indirect capital costs | 15% equipment cost |
| Floor space cost | \$50/ft ² (unit size = 64 ft ²) |
| Annual maintenance costs | 10% equipment cost |
| Power cost | \$0.05/kWh |
| Depreciation | 10 years at 10% per year |
| Annual costs based on the above: | |
| Equipment costs | \$19,000 |
| Operating costs | \$53,000 |
| Cost per mass of VOC destroyed | \$7/lb (\$15/kg) |

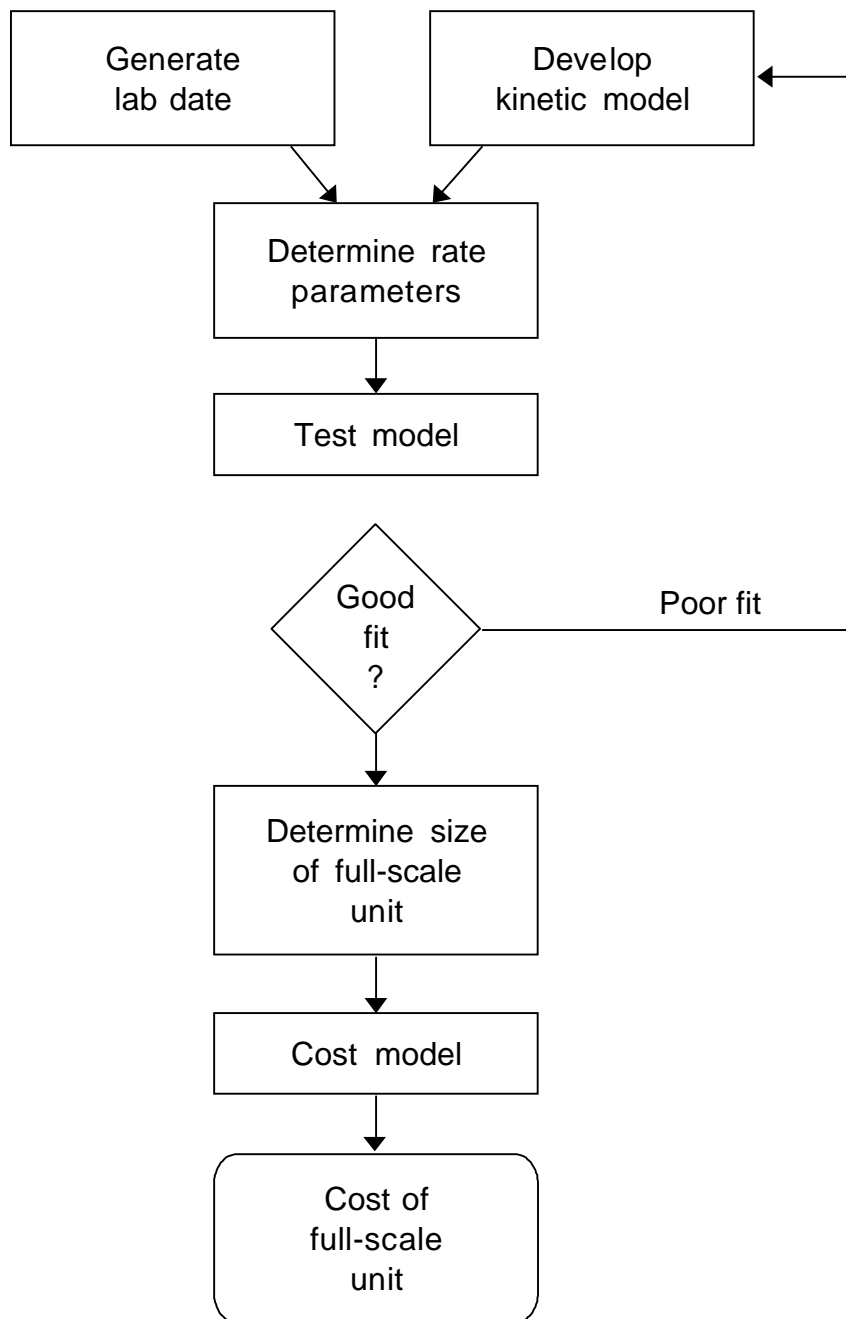

Figure 8 Sequence of PCO Cost Modeling

4 CONCLUSIONS AND RECOMMENDATIONS

PCO has been proven to rapidly destroy isopropanol, acetone, and methanol, contaminants typical to parts cleaning sinks. Under the conditions examined, >95% of the VOCs was converted to carbon dioxide and water. At slightly elevated temperatures, approximately 6% of the incoming carbon was converted to CO. In the laboratory photoreactor, the simulated effluent required a residence time of 4 seconds for the 95% conversion at room temperature. This value dropped to 1 second when the temperature was increased to 70°C.

Initial scale-up calculations suggest that these base-case reaction rates need to improve if the estimated cost of ownership is to be lowered. NREL will next test modifications to the baseline conditions. Previous work has shown three basic means to increase the process rate:

- Increase temperature
- Improve the efficiency of the catalyst
- Add oxidants to the system

Increasing the temperature from 25°C to 70°C was shown to increase the reaction rate by a factor of almost four. However, going much higher than 70°C creates materials issues, as inexpensive plastics can no longer be used for reactor parts. Higher temperatures may also require active heating rather than a simple reliance on the thermal output of UV lamps. NREL is investigating new catalyst formulations for both gas-phase and water-phase PCO. This work has already demonstrated significant rate improvements for certain applications. The most promising new catalysts will be tested for these air streams.

When treating aromatic compounds such as benzene, adding ozone was found to significantly reduce the required size of a PCO system and reduce overall treatment cost. Although ozone has been the oxidant of choice for applications involving aromatics, hydrogen peroxide is effective at increasing the reaction rates of alcohols. For example, Figure 9 shows a rate increase by a factor of six to eight when small amounts of hydrogen peroxide were added to the air stream.

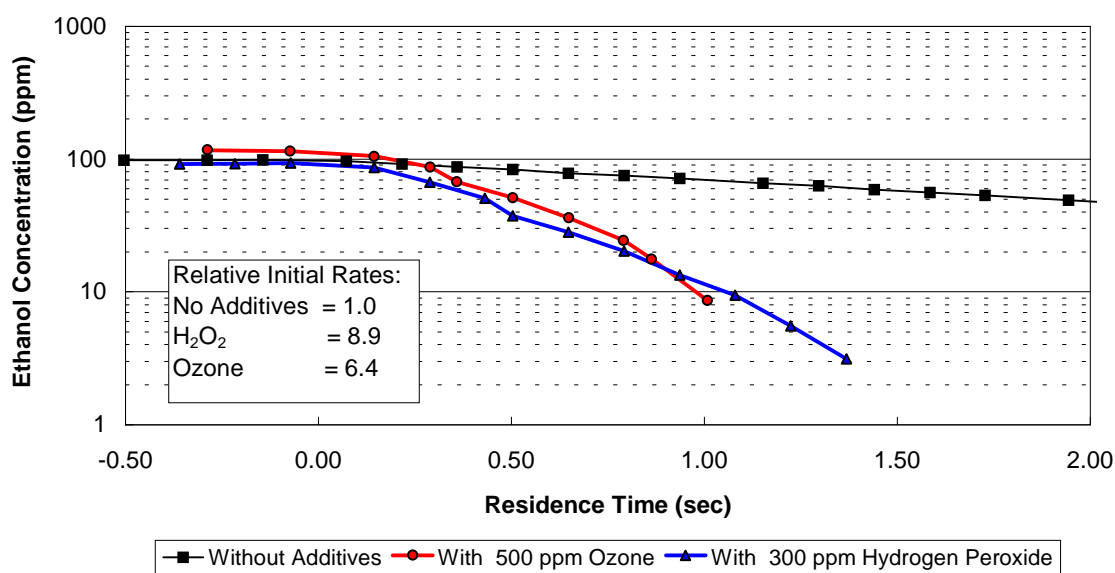

Figure 9 Effect of Oxidant Addition on Rate of Ethanol Degradation

For applications where it is effective, hydrogen peroxide is preferred over ozone because it involves low capital investment and has a low operating cost. The limited volatility of hydrogen peroxide creates some problems, but these can be overcome by a proper feed system design. Hydrogen peroxide will next be investigated as a rate enhancer.

5 FUTURE WORK

On the basis of the results in this report, the following work is being pursued:

- Testing modified catalysts being developed through other PCO research at NREL to determine if they demonstrate improved efficiency for these solvents
- Adding hydrogen peroxide to the air stream to increase oxidation rates
- Testing hexamethyldisilazane (HMDS) to determine its reactivity in a PCO system
- Identify all by-products from PCO treatment

Once the effects of the first two adjustments are addressed, the economics of PCO for treating the parts cleaning sink emissions will be reassessed. Item three addresses PCO's applicability to treat the air emissions from photolithography tracks. The optimized PCO process will be field-tested at semiconductor manufacturing facility.

6 REFERENCES

- [1] Turchi, C. S., E. J. Wolfrum and R. A. Miller, "Gas-Phase Photocatalytic Oxidation: Cost Comparison with Other Air Pollution Control Technologies," NREL/TP-471-7014, Presented at: Advanced Oxidation Technologies for Water and Air Remediation, London, Ontario, Canada, June 25-30, 1994.
- [2] AIChE Center for Waste Reduction Technologies, *Current and Potential Future Industrial Practices for Reducing and Controlling Volatile Organic Compounds*, American Institute of Chemical Engineers, New York, September 1992.
- [3] "Air Pollution Control," *Chem. Engrg. Prog.*, Vol. 89, No. 7, 19-41, (1993).
- [4] Notarfonzo, R. and W. McPhee, "How to Evaluate a UV/Oxidation System," *Pollution Engineering*, 74-76, October 1994.

**SEMATECH Technology Transfer
2706 Montopolis Drive
Austin, TX 78741**

<http://www.sematech.org>